

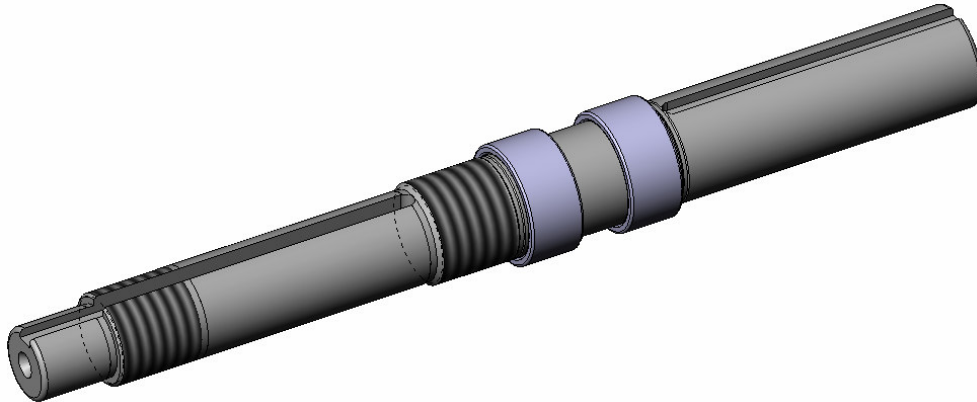

New Product Bulletin

1263-119-5-NB-RK

Needle Bearing Style Countersink Lever Stud Retrofit Kit



This is a *Patent Pending* update to our standard **1263-119-5 Countersink Lever Stud**. The new lever stud assembly uses precision needle bearings running on a hard steel shaft to greatly increase the rigidity and service interval of the Countersink Lever. In the most demanding applications, retrofitting your machines with this design can increase your service interval from as little as a few weeks with bronze bushings, to years with the new needle bearings. In typical applications, bearing life can exceed 5 years. More importantly, it *virtually eliminates* countersink arm chatter due to worn studs and bushings, as a reason for out-of-tolerance parts. If you are having difficulty with a job because of chatter in your countersinking and back-working tools, you need to try a 1263-119-5-NB-RK on your machine. It can be installed in minutes, and the ZERO CLEARANCE design is the perfect compliment to any machine using the 627-NB Needle Bearing Tool Arm Studs, or the Zero-Clearance Dovetail Expansion Gib technology available in our 132EG 1st and 2nd position slides, and 131EG 4th position slides. The 1263-119-5-NB-RK retrofit kit includes only the stud and bearings.

New Features:

- Virtually Eliminates Countersink Lever chatter.
- Lower *long-term* cost of ownership with reduced repair costs and less scrap.
- 100% interchangeability with genuine Davenport Machine OEM parts.
- Installs in minutes with no machine modifications.

Davenport Machine OEM parts are constantly being redesigned to maximize the *value* to the customer. Any parts supplier can sell you yet another *replacement* part for your *problem*. Let the team at Davenport Machine supply you with a cost effective *solution* to it instead. Contact your local distributor, or call us directly at 1-800-344-5748 and ask about our many new and improved products that will help put profits back where they belong... in your pocket.

Visit us at www.davenportmachine.com today to see all of our New Product Bulletins