

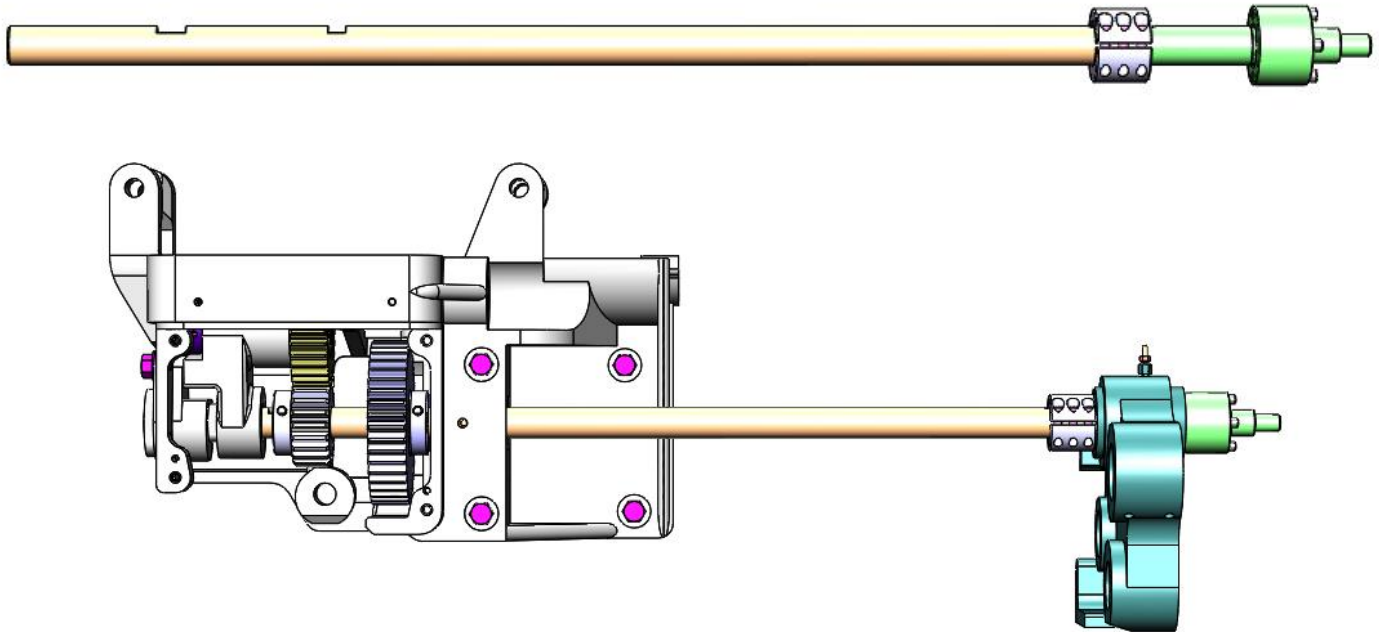

NEW Product Bulletin

5080-226-49-2PC-SA

Model B 2-Piece Threading Shaft



This upgraded version of our standard 5080-226-49-SA **Model B Threading Shaft** is split and coupled just to the left of the spindle change gears. The greatest benefit comes during set-up changes and service of the **Model-B Threading Clutch**. The center coupling can be loosened, and the entire threading clutch attachment can be removed with ease. This allows servicing of the unit without disassembly and removal of the shaft through the spindle drive housing, saving hours of costly machine downtime at every set-up and service. In addition, the new design allows the quick and economical replacement of only the spindle drive gear end of the shaft, which can become damaged during machine crashes or worn with continuous use. Also available for Long-Bed Model-B's.

New Features:

- Lower *initial & long-term* cost of ownership with reduced set-up and repair costs.
- Reduce downtime up to 1.5 hours each time you remove or replace this shaft.
- 100% interchangeability with genuine Davenport Machine OEM parts.
- 100% of the performance of the standard design.

Davenport Machine OEM parts are constantly being redesigned to maximize the *value* to the customer. Any parts supplier can sell you yet another *replacement* part for your *problem*. Let the team at Davenport Machine supply you with a cost effective *solution* to it instead. Contact your local distributor, or call us directly at 1-800-344-5748 and ask about our many new and improved products that will help put profits back where they belong... in your pocket.